



A NEW FRONTIER IN IMMUNO-ONCOLOGY

CHINA HEALTHCARE SUMMIT 2018
SHANGHAI

LSE: SCLP.L

DR RICHARD GOODFELLOW
FOUNDER, BOARD DIRECTOR
AND FORMER CEO

November 2018

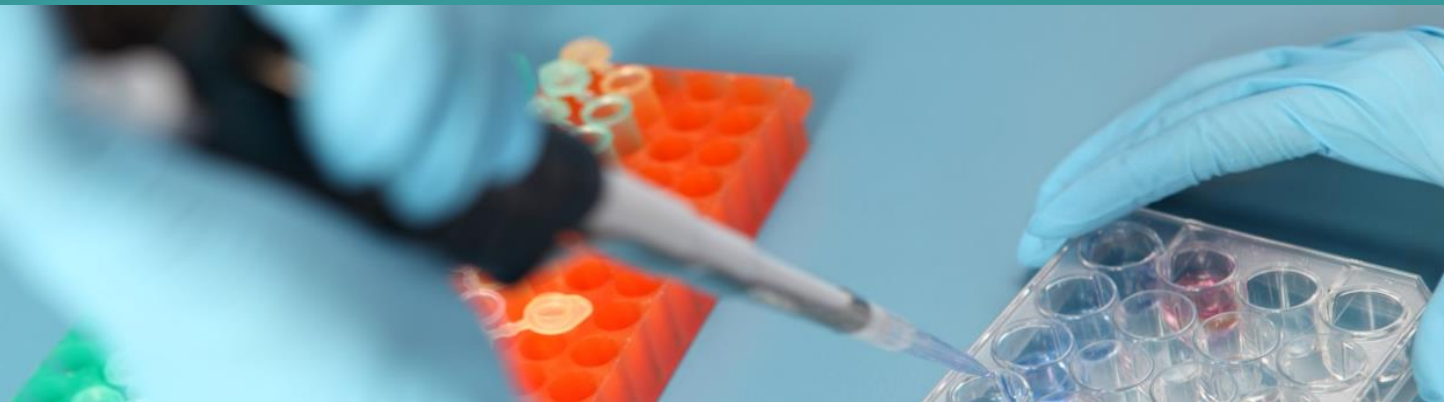



DISCLAIMER

The information contained in these slides has been prepared by Scancell Holdings plc (the "Company"). It has not been approved by the United Kingdom Financial Conduct Authority under the Prospectus Rules (made under Part VI of the Financial Services and Markets Act 2000) or otherwise, or by the London Stock Exchange plc. Nothing in these slides, nor in any information communicated to you in the presentation of these slides, constitutes or forms part of any offer for sale or solicitation of any offer to buy or subscribe for any securities in any jurisdiction nor shall these slides, such presentation or any part of them form the basis of or be relied on in connection with, or act as any inducement to enter into, any contract or commitment whatsoever. No reliance may be placed for any purpose whatsoever on the information or opinions contained in these slides or the presentation of them or on the completeness, accuracy or fairness thereof.

No undertaking, representation, warranty or other assurance, express or implied, is or will be made or given by or on behalf of the Company or its directors, officers, partners, employees, affiliates, representatives, agents or advisers (together, the "Affiliates") or any other person as to the accuracy or completeness of the information or opinions contained in these slides and/or the presentation of them and no responsibility or liability is accepted by any such person for any such information or opinions or for any errors, omissions or misstatements, negligent or otherwise, nor for any other communication written or otherwise. In addition, neither the Company nor any of its Affiliates undertakes any obligation to update or to correct any inaccuracies which may become apparent. Notwithstanding the aforesaid, nothing in this paragraph shall exclude liability for any representation, warranty or other assurance made fraudulently.

The statements contained in these slides and/or the presentation of them may include "forward-looking statements" that express expectations as to future events or results. Forward-looking statements can be identified by the use of forward-looking terminology, including the terms "believes", "estimates", "anticipates", "projects", "expects", "intends", "may", "will", "seeks" or "should" or, in each case, their negative or other variations or comparable terminology, or by discussions of strategy, plans, objectives, goals, future events or intentions. These statements are based on current expectations and involve risk and uncertainty because they relate to events and depend upon circumstances that may or may not occur in the future. There are a number of factors which could cause actual results or developments to differ materially from those expressed or implied by such forward-looking statements. Any of the assumptions underlying forward-looking statements could prove inaccurate or incorrect and therefore any results contemplated in forward-looking statements may not actually be achieved. Nothing contained in these slides and/or the presentation of them should be construed as a profit forecast or profit estimate. Investors and any other recipients of such communications are cautioned not to place reliance on any forward-looking statements. The Company undertakes no obligation to update or revise (publicly or otherwise) any forward-looking statement, whether as a result of new information, future events or other circumstances.

Neither these slides nor the presentation of them should be considered a recommendation by the Company or its Affiliates in connection with any purchase of or subscription for securities of the Company. You are encouraged to seek individual advice from your personal, financial, legal, tax and other advisers before making any investment or financial decisions subscribing for or purchasing any of the Company's securities.

These slides should not be copied or distributed by recipients and, in particular, should not be distributed by any means, including electronic transmission, to persons with addresses in the United States of America, Canada, Australia, Republic of South Africa, New Zealand or Japan, their possessions or territories or to any citizens thereof, or to any corporation, partnership or such entity created or organised under the laws thereof. Any such distribution contrary to the above could result in a violation of the laws of such countries.

Any reference to any provision of any legislation in this document shall include any amendment, modification, re-enactment or extension thereof.

These slides and their contents are confidential and are being supplied to you solely for your information and may not be reproduced, re-distributed or passed on, directly or indirectly, to any other person or published in whole or in part for any purpose. By accepting receipt of this document, you agree to be bound by the limitations and restrictions set out above.



DIFFERENTIATED IMMUNO-ONCOLOGY CLINICAL STAGE OPPORTUNITY

COMPANY FACTS AND FIGURES

- ▶ Founders Prof Lindy Durrant and Dr Richard Goodfellow
- ▶ Corporate office based in Oxford, UK
- ▶ 23 employees (10 PhD's)
- ▶ AIM listed (SCLP)

PROPRIETARY TECHNOLOGY PLATFORMS

- ▶ Novel immunogenic antigens and modulation mechanisms that stimulate potent T-cell responses for the treatment or prevention of cancer
- ▶ Unique mode of action of **IMMUNOBODY**[®] and **MODITOPE**[®] immunotherapies stimulate immune responses by presenting cancer antigens to trigger potent killer T-cell activation

CLINICAL STAGE COMPANY

- ▶ Four lead products in development
- ▶ Lead product has completed a Phase 1/2 study in melanoma
- ▶ Further clinical studies in preparation targeting multiple cancer indications

2 PLATFORMS, 4 LEAD PRODUCTS + MULTIPLE CANCER INDICATIONS



MEETING THE NEED FOR EFFECTIVE THERAPEUTIC CANCER VACCINES

- ▶ Key challenge is to stimulate an effective T cell response to reject or kill the growing tumour
- ▶ Most vaccine strategies only stimulate low frequency, low avidity T cell responses that fail to control tumour growth
- ▶ Scancell's novel therapies stimulate **high avidity** CD8 and/or CD4 T-cells that efficiently kill tumours

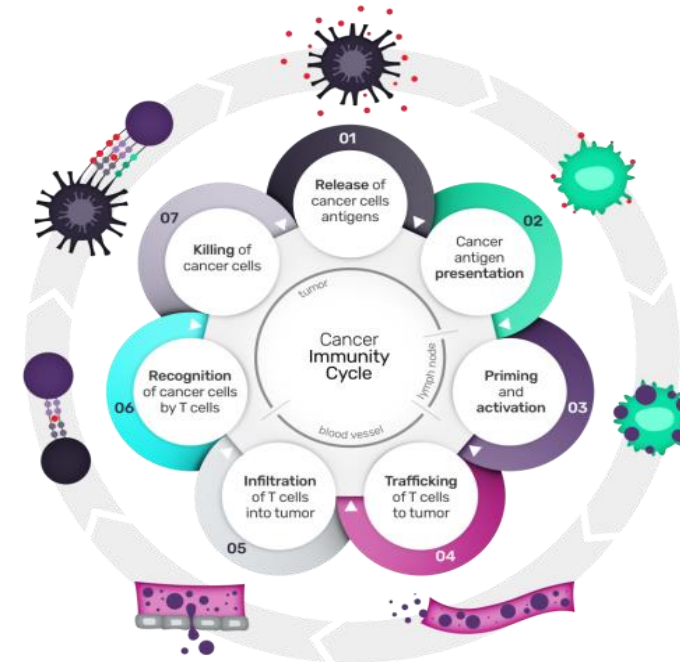

Ref: Chen and Mellman 2013

TWO DIFFERENTIATED PLATFORMS

IMMUNOBODY®

- ▶ DNA-based platform generates high avidity CD8 T-cells by presenting T-cell epitopes of known cancer antigens through a unique dual mode of action

MODITOPE®

- ▶ Modified peptides that generate potent killer CD4 T-cells to target antigens induced by stress-induced post-translational modifications (siPTM vaccines)



DEVELOPMENT PIPELINE

IMMUNOBODY®

- ▶ **SCIB1:** Targets malignant melanoma. Phase 1/2 study completed with strong survival data. Phase 2 combination trial with immune checkpoint inhibitor starting 1H19.
- ▶ **SCIB2:** Targets NSCLC. Phase 1/2 combination trial with immune checkpoint inhibitor to be funded and sponsored by Cancer Research UK (CRUK).

MODITOPE®

- ▶ **Modi-1:** Manufacturing process development initiated. Phase 1/2 trial in TNBC, ovarian and sarcoma planned for 2019.
- ▶ **Modi-2:** Targets multiple solid tumours. In preclinical development.
- ▶ **TCR collaboration:** To clone and characterise T cell receptors against Modi-1 specific epitopes.

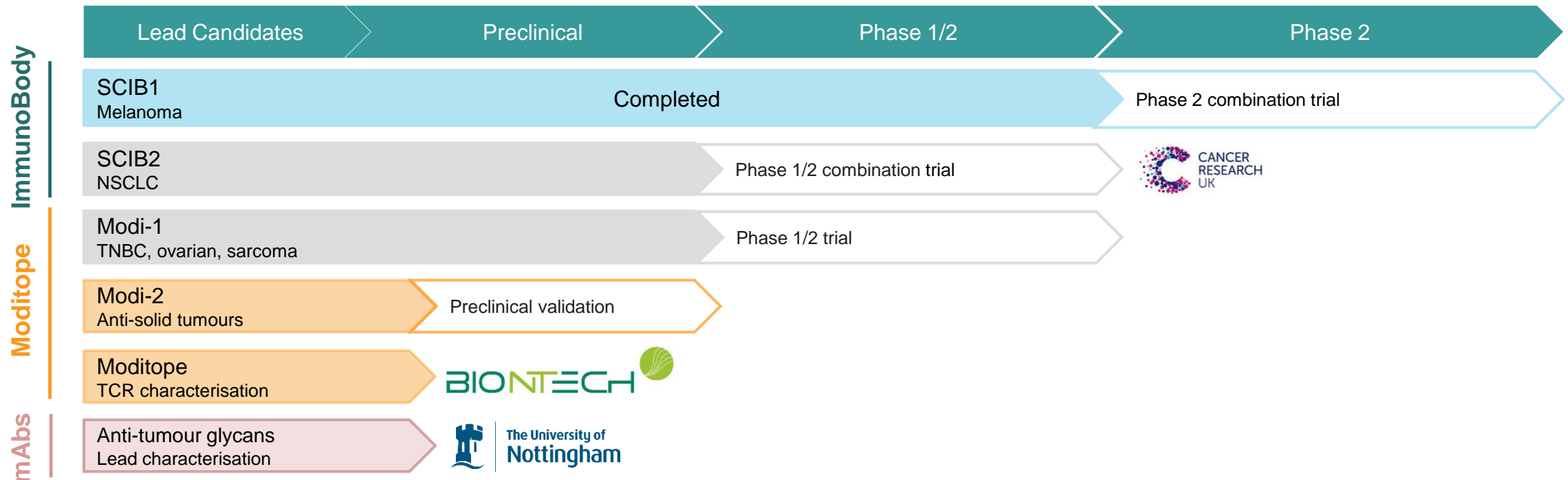



THE MODITOPE® PLATFORM

A NOVEL IMMUNOTHERAPY THAT OVERCOMES IMMUNOSUPPRESSION AND DELIVERS UNPRECEDENTED KILLER T-HELPER CELL RESPONSES

Stress-Induced Post-translational Modifications siPTM

- ▶ One such modification involves the process of **CITRULLINATION**
 - ▶ *Involves the alteration of proteins due to enzymatic conversion of arginine residues to citrulline*
 - ▶ *Citrullination occurs as a result of a degradation and 'recycling' process called **autophagy** that is induced in stressed cells, including cancer cells*

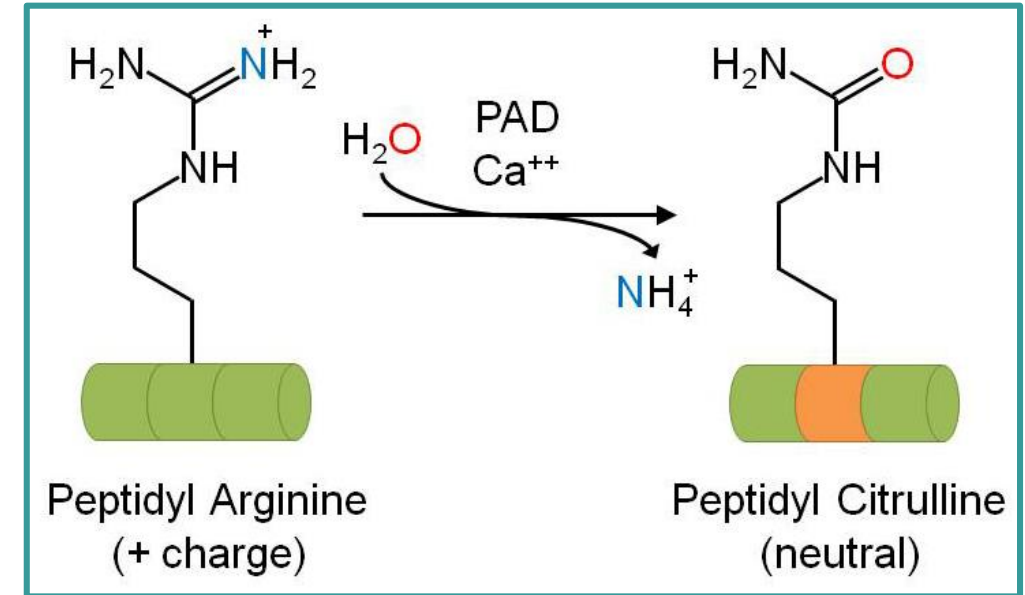

PAD = peptidylarginine deiminase

- ▶ The Moditope® platform is based on exploiting this normal immune response to stressed cells, which is largely mediated by cytotoxic CD4 T cells
- ▶ The novelty of the technology is harnessing this mechanism to eradicate tumour cells by immunizing with citrullinated peptides
- ▶ **Patent awarded in Europe, Japan, China, Australia; for any citrullinated peptide for the treatment of cancer**



▶ Second siPTM involves the process of **HOMOCITRULLINATION**

- ▶ the alteration of proteins due to non-enzymatic conversion of lysine residues to homocitrulline
- ▶ Homocitrullination occurs as a result of MPO released by myeloid-derived suppressor cells (MDSC) which converts thiocyanate to cyanate in the presence of H_2O_2
- ▶ Cyanate diffuses into tumour cells and results in spontaneous homocitrullination of cytoplasmic proteins
- ▶ These proteins are degraded during **autophagy** and homocitrullinated epitopes presented on **MHC class II**
- ▶ Patent filed with broad claims in cancer and composition of matter for any use of homocitrullinated peptides

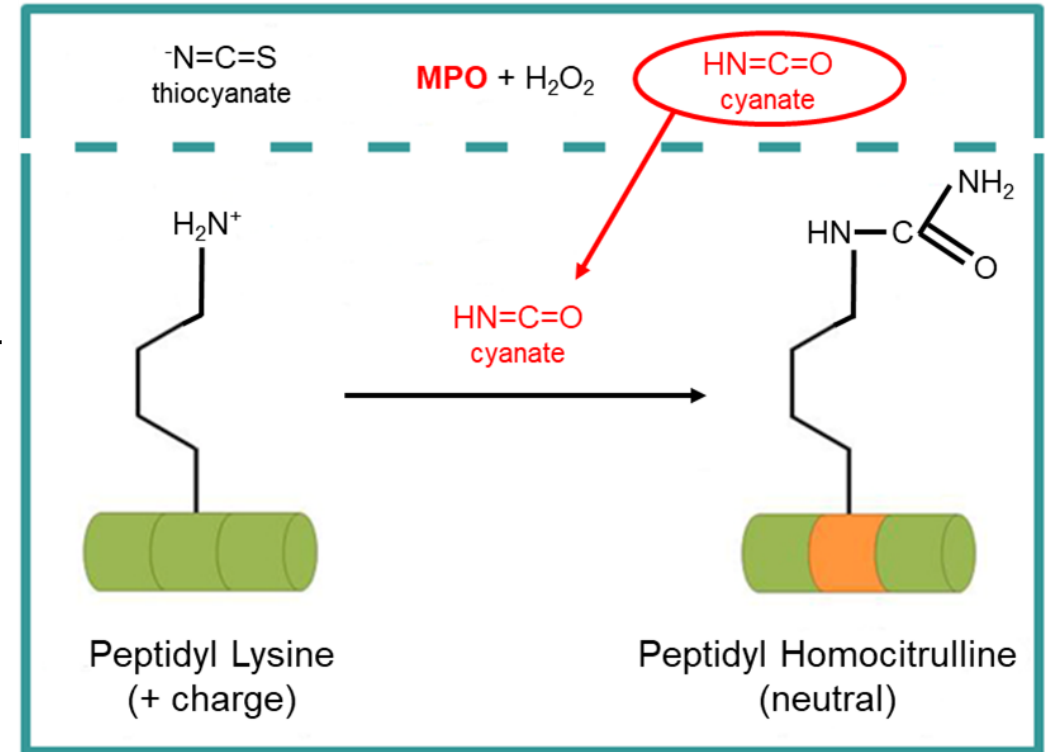

MPO = myeloperoxidase



MODITOPE® LEAD CANDIDATE

Modi-1

- ▶ Consists of:
 - ▶ Two citrullinated vimentin peptides (Vim-1 and Vim-2)
 - ▶ One citrullinated enolase peptide (Eno-1)
- ▶ Vimentin and enolase targets are highly expressed in triple negative breast cancer (TNBC) (90%), ovarian cancer (95%), and sarcoma (100%) - all with high unmet medical need
- ▶ Modi-1 induced potent anti-tumour responses
- ▶ Covalent linkage to Amplivant® (TLR-2 ligand as adjuvant) increases potency 100-fold
- ▶ **A single immunization of Modi-1 resulted in a 100% survival rate in animal models**

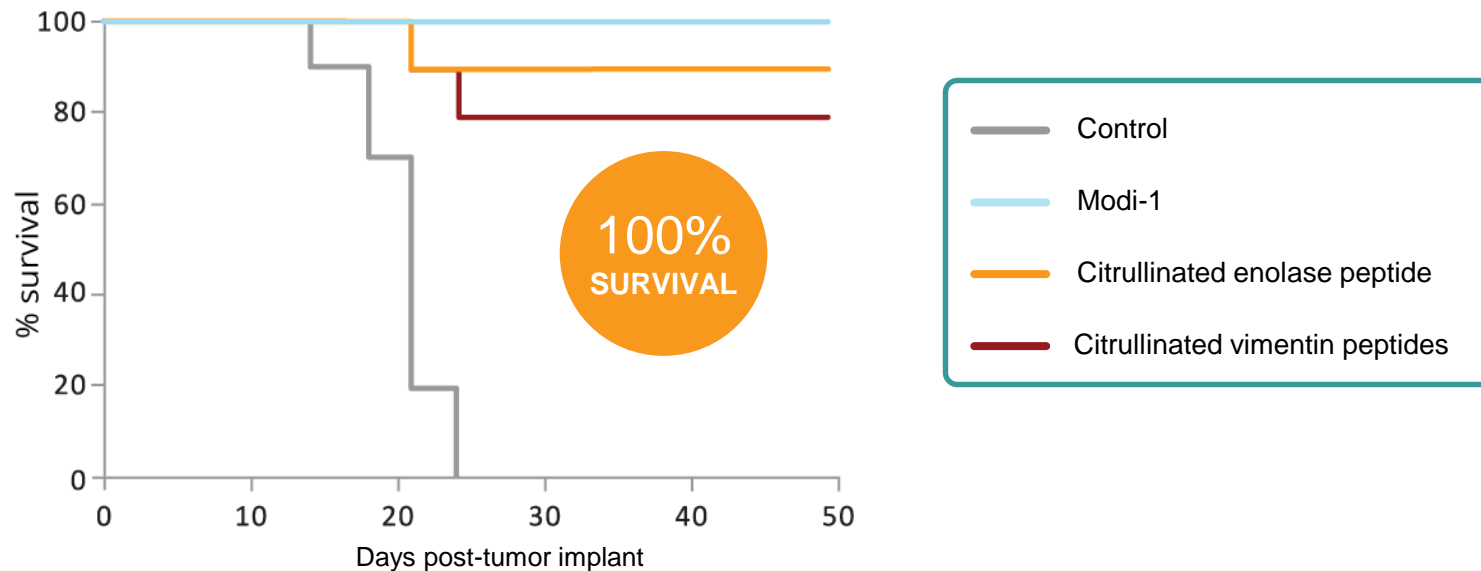



PATIENT POPULATION

- ▶ Patients with tumours with high vimentin or enolase expression (e.g., sarcoma, triple negative breast cancer, ovarian)
- ▶ Failed or intolerant to standard of care therapies

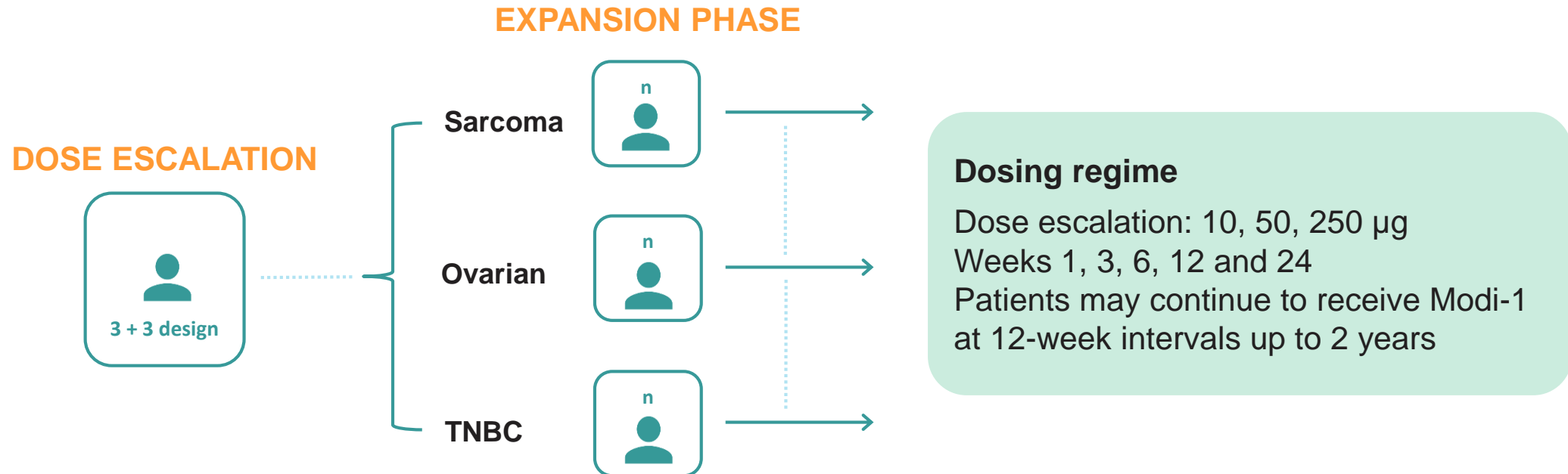

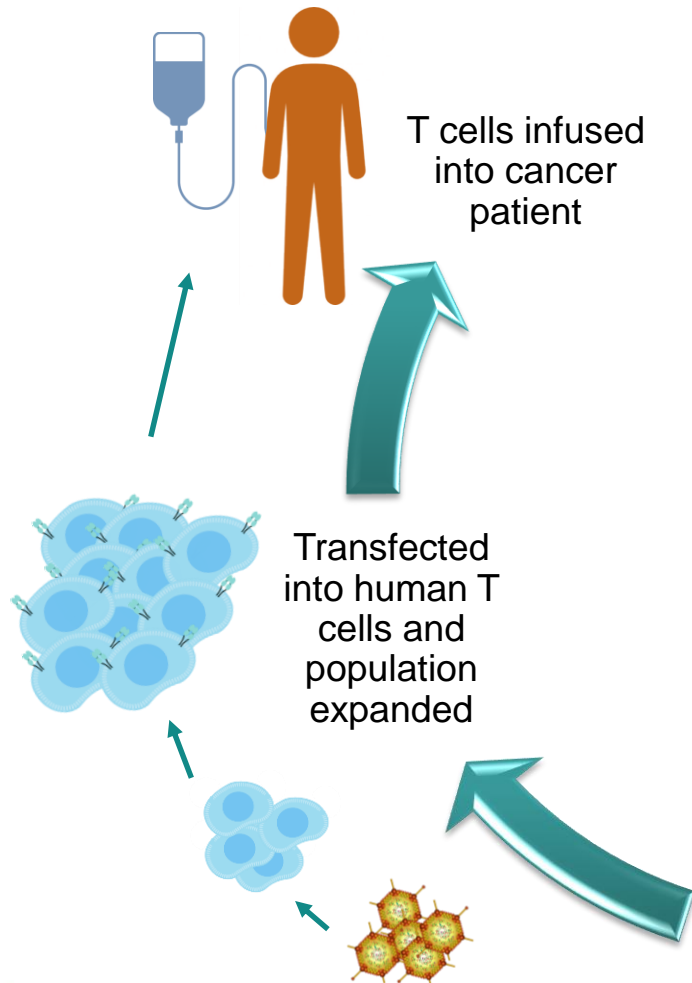

ADVANTAGES OF CITRULLINATED & HOMOCITRULLINATED ANTIGEN-SPECIFIC TCRS

- ▶ Citrullinated & homocitrullinated antigens are expressed by a wide range of tumours
- ▶ Citrullinated & homocitrullinated antigen-specific T cells recognise the non-polymorphic HLA-DP4 so are applicable to at least 70% of patients
- ▶ Citrullinated and homocitrullinated antigen-specific T cells stimulate potent anti-tumour immunity

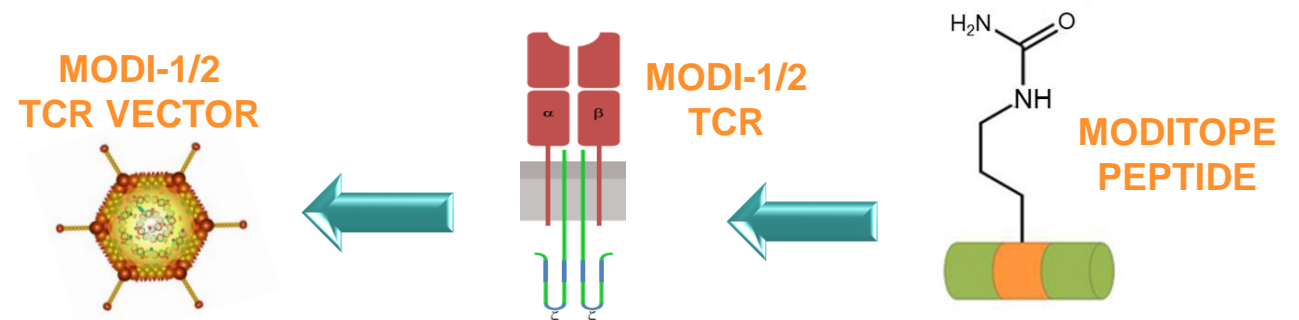



MODITOPE MILESTONES

EXTERNAL VALIDATION OF MODITOPE® PLATFORM

INTERNAL PROJECTS ADVANCED AND EXPANDED

MODITOPE®

- ▶ Research collaboration to develop T-cell based therapies established with BioNTech
- ▶ License agreed with ISA Pharmaceuticals for development of Amplivant® Modi-1 conjugate therapy
- ▶ GMP manufacturer contracted for production of Modi-1/Amplivant® conjugate
- ▶ Modi-1 clinical study expected to start in CY19
- ▶ Homocitrullinated peptides under evaluation for inclusion in new Modi-2 vaccine targeting multiple solid tumours
- ▶ Strong Patent protection
- ▶ Shortlisted for CRUK Grand Challenge award;



THE IMMUNOBODY® PLATFORM

- ▶ Proprietary patent protected platform
- ▶ Several cancer associated T cell epitopes are engineered into a human antibody framework to make a genetic antigen/antibody complex
- ▶ Delivered as a DNA plasmid using electroporation

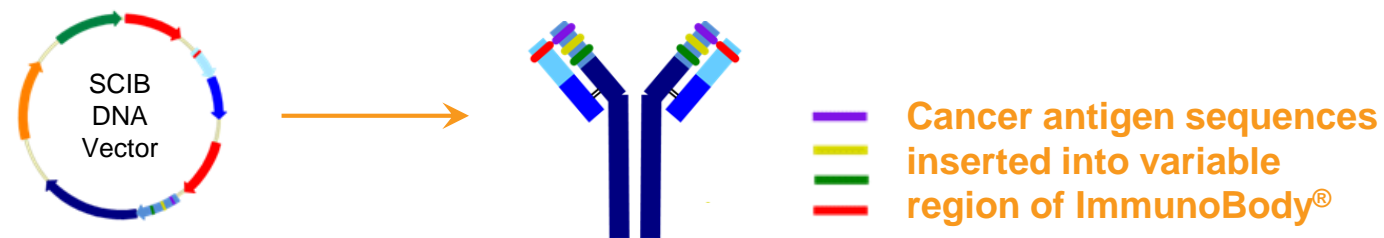

- ▶ Nano-vesicle delivery under evaluation
- ▶ Novel dual mechanism of action based on **direct** and **cross-presentation**
- ▶ SCIB1 for melanoma (**TRP-2/gp100 melanoma associated antigens**): Phase 1/2 clinical trial complete, Phase 2 planned
- ▶ SCIB2 for lung cancer (**NY-ESO-1**): Clinical development partnership with CRUK



SCIB1 IN PATIENTS WITH MELANOMA

SCIB1 has an excellent safety profile with no dose-limiting toxicities and no serious adverse events related to study drug or delivery device

TUMOUR RESPONSE

Patient with tumour received 8 mg SCIB1 and showed a marked reduction in size of detectable lung lesions

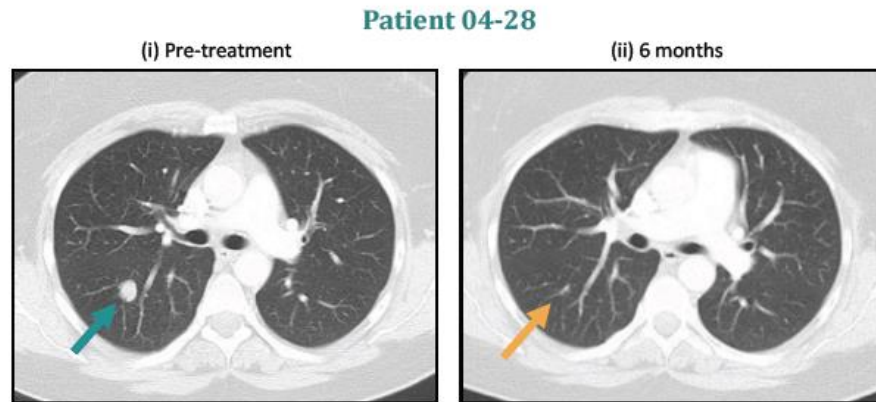

SURVIVAL IN RESECTED PATIENTS

- ▶ Overall survival with SCIB1 treatment superior to historical survival rates
- ▶ 14 of 16 resected patients receiving 2-4 mg doses have survived for more than 5 years (February 2018)
- ▶ Melanoma recurrence rates are lower in SCIB1-treated patients than historical controls

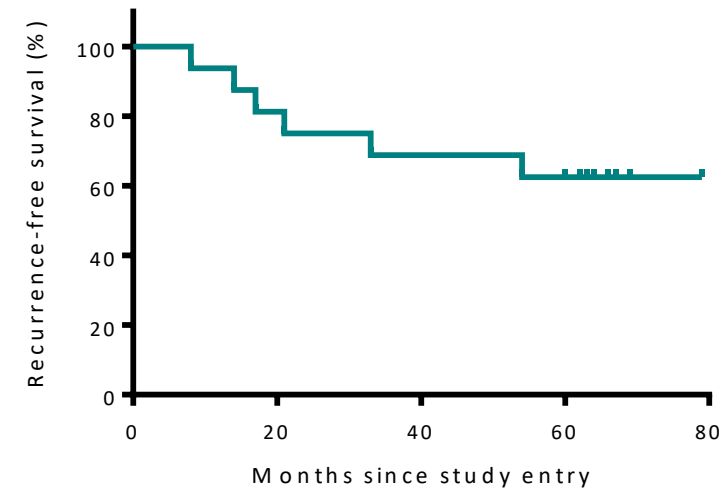



SCIB1 IN MELANOMA PATIENTS

PATIENTS WITHOUT TUMOUR PRESENT AT STUDY ENTRY

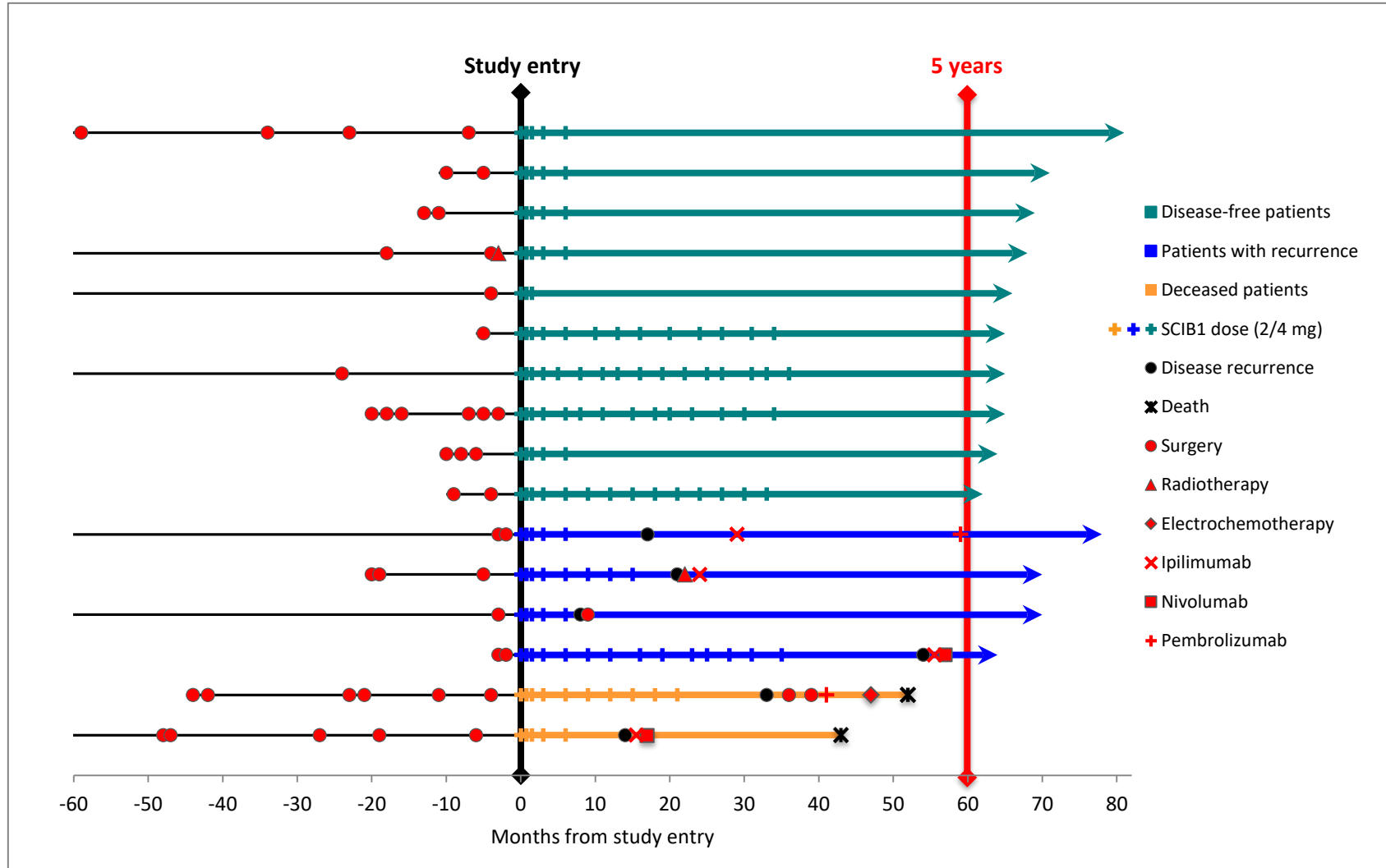



SCIB1 BOOSTS IMMUNE CHECKPOINT THERAPY

IN A MOUSE MELANOMA MODEL, SURVIVAL RATES WERE SIGNIFICANTLY BOOSTED WHEN ANTI-PD-1 THERAPY WAS COMBINED WITH SCIB1 TREATMENT

- ▶ Survival rates for SCIB1 ImmunoBody[®] monotherapy \approx anti-PD-1
- ▶ Monotherapy viable option for resected melanoma patients
- ▶ Combination therapy resulted in an 85% survival rate
- ▶ SCIB1 also upregulates PD-L1 expression and memory response

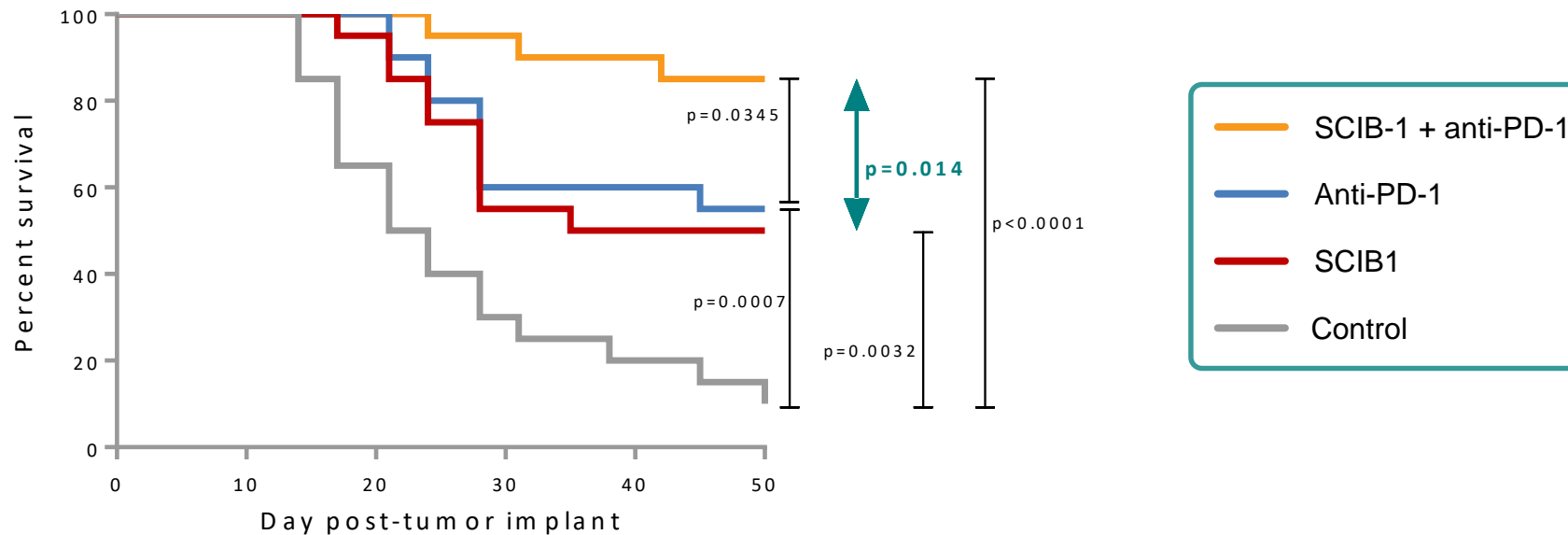



SCIB1 PLUS CHECKPOINT INHIBITOR COMBINATION PHASE 2 STUDY DESIGN

PATIENT POPULATION

- ▶ Histologically confirmed, unresectable AJCC stage III or stage IV melanoma
- ▶ No prior systemic treatment for advanced disease
- ▶ Suitable for treatment with Keytruda (pembrolizumab), with measurable disease
- ▶ Part 1 – safety run-in (n=6); Part 2 – additional 19 patients; total = 25 patients

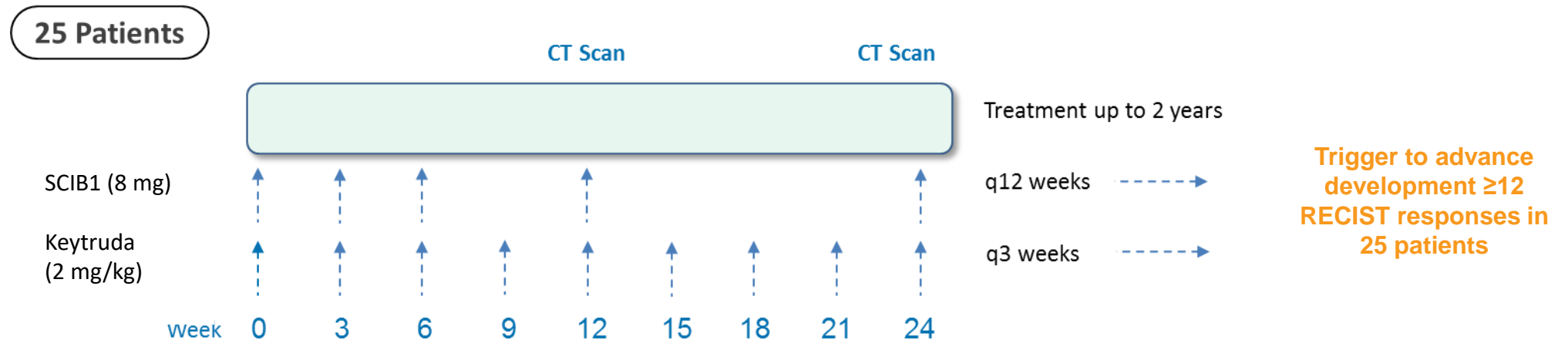

Assumptions

- ▶ Response rate to Keytruda = 30%
- ▶ Response rate of interest for combination = 55%



SCIB1 IND REVIEW PROCESS

- ▶ IND submitted
- ▶ Reviewed by FDA
 - ▶ SCIB1 clinical and toxicology questions answered during review process
 - ▶ CMC questions under control
- ▶ Ichor TriGrid v2.0 device Master File
 - ▶ Device-specific questions
 - ▶ Responses being prepared by Ichor in consultation with Scancell
- ▶ Complete response required for review by FDA
- ▶ Continue to plan for study start in UK and US, subject to regulatory approval
- ▶ Studies in China in patients with mucosal melanoma?





IMMUNOBODY®

SCIB1

- ▶ In combination with checkpoint inhibitors in patients with late stage disease to increase efficacy without compromising safety
- ▶ As monotherapy in patients with resected disease (adjuvant setting) to delay or prevent recurrence

SCIB2

- ▶ Lung cancer huge unmet medical need; deaths per year greater than melanoma, colon, breast and prostate cancers combined
- ▶ Checkpoint inhibitors less effective in lung cancer, with 80% of patients requiring a better SOC

MODITOPE®

Modi-1 & Modi-2

- ▶ siPTM vaccine class
- ▶ Innovative mechanism of action potentially targets all solid tumours
- ▶ Modi-1 and Modi-2 will target tumours that are unresponsive to existing immunotherapy (turning “cold” tumours to “hot”)
- ▶ Identification of Modi-specific TCRs provides a novel pathway for CD4-based TCR therapy



IMMUNOBODY®

SCIB1

- ▶ SCIB1/checkpoint inhibitor Phase 2 US/UK combination study in late stage melanoma, planned to start 1H19, subject to regulatory submissions

SCIB2

- ▶ CRUK development activities for initiation of SCIB2 Phase 1/2 study for NSCLC

MODITOPE®

Modi-1

- ▶ Preparation for the First-In-Human study with Modi-1 in patients with TNBC, ovarian cancer and sarcoma planned to start CY19
- ▶ Identification of Modi-specific TCRs in collaboration with BioNTech

Modi-2

- ▶ Pre-clinical development for multiple solid tumour indications
- ▶ Extension of patent portfolio



FUTURE VALUE DRIVERS

2 PLATFORMS, 4 LEAD PRODUCTS + 5 CORE ACTIVITIES

CLINICAL DATA

- ▶ Generate meaningful clinical data to address unmet needs: clinical read-outs (SCIB1 Phase 2 & Modi-1 Phase1/2 pt 1) anticipated in next 2 years

PIPELINE EXPANSION

- ▶ Extend utility of Moditope platform beyond Modi-1 and Modi-2 in association with key industry players e.g., TCRs
- ▶ Lead generation and optimisation of anti-glycan mAbs

GLOBAL EXPANSION

- ▶ Extend clinical trial footprint to US in 2019
- ▶ Explore partnerships in China (financial and commercial)

CLINICAL PARTNERSHIPS

- ▶ Establish relationships with key opinion leaders and clinical networks to ensure utility in clinical practice e.g., CRUK and patient advocacy groups

INDUSTRY PARTNERSHIPS

- ▶ Explore synergies with large Pharma/Biotech companies in identifying combination therapies for optimal outcomes e.g., checkpoint inhibitors

